

DATA _____

VI	MARCHIO DI FABBRICA TRADE MARK
A	CONTRASSEGNO TIPO VETRO GLASS TYPE
00	NUMERO STAMPO CAVITY NUMBER
2	ZIGRINATURA KNURLING
3	PUNTI LETTORE CAVITA' DOTE CODE
4	CODICE ALFANUMERICO NUMERIC CODE
5	GODRONATURA A DISCREZIONE DELLA VETTERIA STIPPLING AT THE DISCRETION OF THE GLASS MAKER
©	CONTROLLO STATISTICO STATISTICAL CONTROL

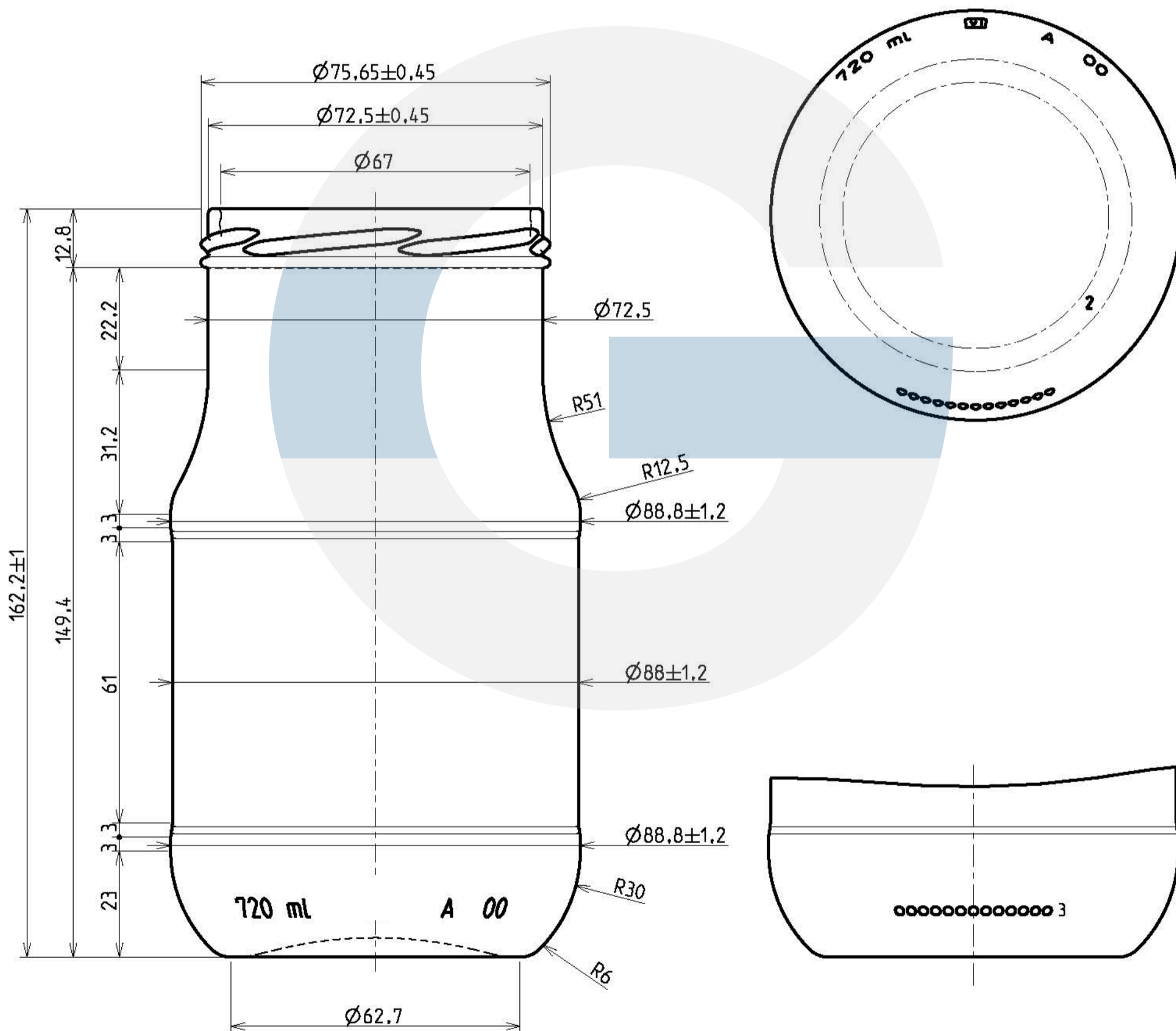

A.1	13/02/17	MaC	corretta bocca	FORMAT
R.V.	DATA	NC	DESCRIZIONE MODIFICA - MODIFICATION DESCRIPTION	A3



ARTICOLO ARTICLE	VASO ATLAS 72-T77	PROGETTISTA DRAWING BY	F. Pagliano	CAPAC. RB (c1) BRIMFULL CAPACITY	72 ±1	©	
BOCCA FINISH	TWIST OFF 77 REGULAR FD 138-E	DATA DATE	02/01/17	PESO (gr) GLASS WEIGHT	~ 338		
CLIENTE CUSTOMER	VARI	ANGOLO DI CADUTA STABILITY	23.7°	APPROVATO DA APPROVED BY	R. Pedrazzi	COD. BOCCA FINISH CODE	B000793_001
DIAMETRO MIN. FORO PASSANTE MINIMUM INTERNAL DIAMETER	59	TOLLERANZA VERTICALITA' VERTICALITY TOLERANCE	± 1	SCALA SCALE	1:1	STUDIO CODE STUDY	ST19476 R.V. A.1